

Model DS1200-AMT

Single Channel Dew Point Hygrometer

User friendly solution for continuous on-line measurement of dewpoint in process gas and dry compressed air, offering powerful functionality and simple interface through advanced digital technology.

FEATURES:

- **User Friendly & Advanced Functionality**
- **DISPLAY in °C Dewpoint & °F Dewpoint, ppm(v), ppb(v), g/m³ or lbs/MMSCF**
- **22V – 253V AC or DC Operation**
- **Linear 4-20mA Retransmission Signal**
- **2 Independent, Fully Programmable Alarm Relays**
- **“AUTOCAL” CALIBRATION FEATURE**
- **Fast Response**
- **Long Term Stability**
- **IP66 / NEMA4 Weatherproof Protection**
- **Calibration to National & International Standards**



Model DS1200 from Alpha Moisture Systems is a single channel on-line hygrometer designed to measure dewpoint in process gases and dry compressed air. The panel mounted ½ DIN dewpoint meter, providing panel protection to IP65 (NEMA4X), combines with the Model AMT range of ultra high capacitance sensors for accurate trace moisture measurement.

Combination of advanced digital technology of the display electronics and the sensor, makes this the system of choice for a wide range of applications where precise indication, control and monitoring is critical.

Model DS1200-AMT system can be factory configured to read in °C dewpoint, °F dewpoint, ppm(v), ppb(v), g/m³ or lbs/MMSCF. The measured value is displayed on a large 4 digit, 13.8mm high, fourteen segment LED display.

The instrument offers two fully programmable alarm relays, which can be independently set across the full operating range of the sensor. An optically isolated analogue signal, linear with the measured unit, is also available to interface with any external device.

Model DS1200-AMT can be supplied with any one of a range of sensors, which have all been specially manufactured to provide long term stability, so ensuring a long and trouble free service life.

The long lasting sensing element offers excellent sensitivity, repeatability and response speed - especially on dry down. Integrated electronics in each sensor allows calibration data to be stored within its memory, making sensors completely field interchangeable.

Each sensor is calibrated to provide overall system accuracy of better than ±2°C dewpoint and supplied with a certificate traceable to international humidity standards.

Model DS1200-AMT also incorporates the invaluable “AUTOCAL” feature for easy field verification of the system response, without recourse to any additional equipment. Accidental or unauthorised operation is prevented by a simple initiation routine.

The system allows the display console to be sited in excess of 1000m from the sensor, connected by a simple twisted pair cable.

Model DS1200-AMT Dewpoint Hygrometer is fully configured according to the customer's specifications and is supplied complete with 2 metres of connecting cable and user manual.

For ease of installation, an optional flow through sample cell can be ordered together with suitable pipe connections.

SPECIFICATIONS

MODEL DS1200-AMT DEWPOINT HYGROMETER

Single Channel Hygrometer

DS1200 DISPLAY INDICATOR SPECIFICATIONS

ENCLOSURE: 1/8 DIN panel mounting ABS case

DISPLAY: 4 digit, 14 segment LED indicator. Red characters 13.8mm high.
Factory set to display in °C, °F, ppm(v), ppb(v), g/m³ or lbs/MMSCF

SUPPLY VOLTAGE: Universal 22Vac - 253Vac 50/60Hz & 20Vdc - 300Vdc 150mA to 15mA

POWER CONSUMPTION: 3.5W Maximum

OUTPUT SIGNAL: Linear 4 to 20mA, fully isolated. Maximum load 800Ω / 16Vdc

ISOLATION: Voltage Test / Operation - 2.3kVac / 250Vac

ALARM RELAYS: 2 independent fully programmable switched contacts. Rated 2A @ 250Vac / 1A @ 24Vdc.

ANNUNCIATORS: AL1 & AL2 LED's on front panel indicating status of each alarm

ELECTROMAGNETIC COMPATIBILITY (EMC):
Emission & Immunity: Complies with EN 61326
LVD 73/23/EEC: Complies with EN 61010-1

UL, STANDARD OF SAFETY: Certified to UL508

WEATHERPROOF CLASSIFICATION: Front panel only - IP65 (NEMA 4X).

WEIGHT: 230 grams

SENSOR & GENERAL SPECIFICATIONS

SENSOR TYPE: Model AMT Dewpoint Sensor

SENSING ELEMENT: Ultra High Capacitance - Aluminium Oxide Type

RANGES:

SDC(F): -100°C to +20°C (-148°F to +68°F) dewpoint	} 0.1 °C / °F resolution
LDC(F): -120°C to +20°C (-184°F to +68°F) dewpoint	
HDC(F): -65°C to +20°C (-85°F to +68°F) dewpoint	

SPX: 1 to 1000 ppm(v)	1ppm resolution
MPX: 0.1 to 100.0 ppm(v)	0.1ppm resolution
LPX: 0.01 to 10.00 ppm(v)	0.01ppm resolution

PBX: 1 to 1000 ppb(v)	1ppb resolution
-----------------------	-----------------

HGX: 0.01 to 10.00 g/m ³	0.01g/m ³ resolution
LGX: 0.001 to 1.000 g/m ³	0.001g/m ³ resolution

LLB: 0.1 to 10.0 lbs/MMSCF	0.1 lbs/MMSCF resolution
SLB: 0.1 to 25.0 lbs/MMSCF	0.1 lbs/MMSCF resolution
HLB: 0.1 to 50.0 lbs/MMSCF	0.1 lbs/MMSCF resolution

NOTE: ppm, ppb, g/m³ & lbs/MMSCF ranges are stated at atmospheric pressure.
Model DS1200 / AMT Dewpoint Hygrometer can be configured to provide corresponding ranges for operation at other constant pressure. This must be stated at time of order.

AUTOCAL: Field calibration / Span check facility. Activated and operated via two button switches on the Sensor Transmitter body. Locked in normal operating mode to avoid tamper.

TRANSMITTER ENCLOSURE: 316 Stainless steel body with size C, DIN EN 175301 connector.

SENSOR PROTECTION: 316 Sintered stainless steel filter - 50 micron

OPERATING PRESSURE: From 1kPa (0.01 barA) to Maximum 35,000kPa (350 barA)

SAMPLE FLOW RATE: Flow independent but ideally 2 to 5 standard litres per minute. Max: 25 litres/min

WEATHERPROOF CLASSIFICATION: IP66 / NEMA4X when Connector mated to Transmitter.

MECHANICAL CONNECTION: 3/4" UNF (16tpi) with integral Viton "O" ring seal.

WEIGHT: Transmitter and connector - 175grams

CABLE: Supplied with 2m length standard two core cable. Nominal diameter 3.4mm, 92ohms/km at 20°C

TEMPERATURE COEFFICIENT: Transmitter temperature compensated for operating range.

REPEATABILITY: Better than ±0.3°C dewpoint

FACTORY CALIBRATION: Supplied with Certificate of Calibration traceable to NPL / NIST

ACCURACY: ± 2°C dewpoint (NPL / NIST traceable for range -90°C to +20°C)

OPERATING TEMPERATURE: -20°C to +60°C

STORAGE TEMPERATURE: -20°C to +70°C

OPERATING HUMIDITY (External): Maximum - 95% RH Non-condensing

WARM UP TIME: 10 seconds

MECHANICAL WARRANTY: 24 months in case of faulty workmanship and defective parts.

CALIBRATION WARRANTY: 12 months (Not valid if sensor subjected to corrosives or mis-use)

ORDERING INFORMATION

Dewpoint Hygrometer Model DS1200-AMT - [XXX]

Includes Display, Sensor & 2m connecting cable

XXX = Choose required range:

SDC: -100°C to +20°C dewpoint
LDC: -120°C to +20°C dewpoint
HDC: -65°C to +20°C dewpoint

SDF: -148°F to +68°F dewpoint
LDF: -184°F to +68°F dewpoint
HDF: -85°F to +68°F dewpoint

SPX: 1 to 1000 ppm(v)
MPX: 0.1 to 100.0 ppm(v)
LPX: 0.01 to 10.00 ppm(v)

PBX: 1 to 1000ppb(v)

HGX: 0.01 to 10.00 g/m³
LGX: 0.001 to 1.000 g/m³

LLB: 0.1 to 10.0 lbs/MMSCF
SLB: 0.1 to 25.0 lbs/MMSCF
HLB: 0.1 to 50.0 lbs/MMSCF

E.g. Dewpoint Hygrometer with range -100 to +20 °C dewpoint, order as: Dewpoint Hygrometer Model DS1200-AMT-SDC

Connection Cable Model CAB-AMT- [XXX]

XXX = Choose required length of Cable

Leave Blank: 2m (Included with Model AMT)
XXX: Insert cable length in metres

(Available in 10m, 15m, 25m, 50m, 75m & 100m lengths)

E.g. For 60 metres of cable, order as: Model CAB-AMT-75

Model SH-AMT Sensor Holder (Optional)

(Flow Through Sample Cell)

MATERIAL OF CONSTRUCTION: 316 grade stainless steel.

PORTS: Inlet & outlet both 1/8" NPTF

PIPE FITTINGS: 2 x Swagelok® male pipe fittings.
(1/4", 1/8" or 6mm OD – inlet / outlet fitting size to be stated at time of order)

MOUNTING PLATE: 68 x 54 x 3mm Passivated mild steel plate with 2 fixing holes - 5.5mm diameter.

WEATHERPROOF CLASSIFICATION: IP66 / NEMA4X – with Model AMT transmitter installed.

WEIGHT: 500grams (includes 2 fittings & mounting plate)

ORDERING INFORMATION

Sensor Holder Model SH-AMT - [X] - [X]

Supplied with Mounting Plate

X = Choose Right Hand Side Pipe Fitting

0: None
4: 1/4"
8: 1/8"
6: 6mm

X = Choose Left Hand Side Pipe Fitting

0: None
4: 1/4"
8: 1/8"
6: 6mm

E.g. For Sensor Holder with two 1/4" fittings, Order as: Model SH-AMT-4-4

Product specification may be subject to change, without prior notice, as part of our ongoing product development programme.

DIMENSIONS

DS1200 DISPLAY

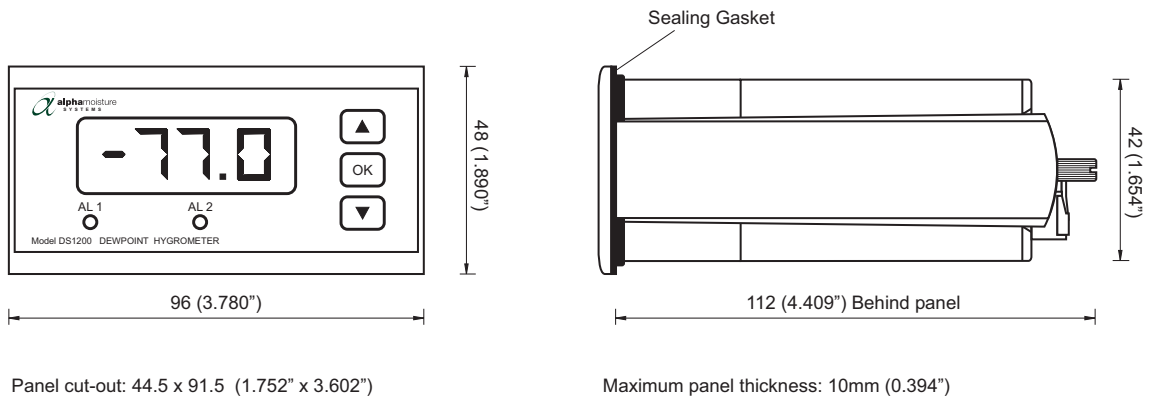

SENSOR

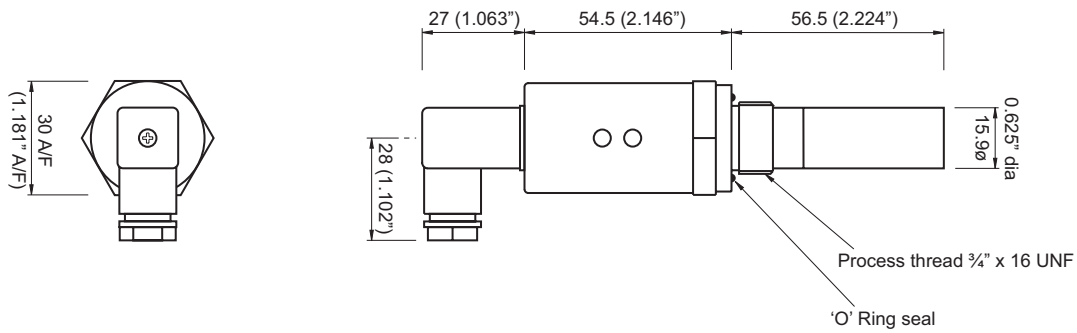

SENSOR HOLDER

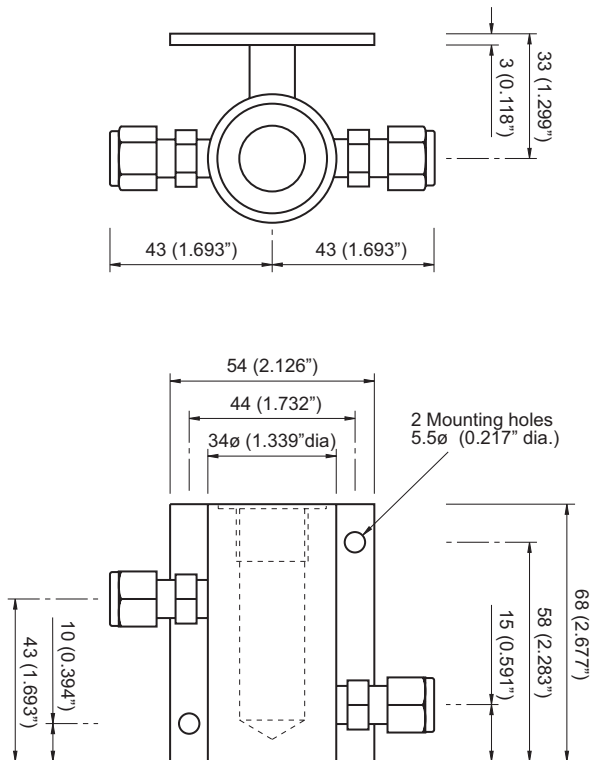

NOTE. The assembly is shown with 1/4" OD tube fittings.
The dimension across the fittings will vary for other tube size fittings.

CONNECTION DETAILS

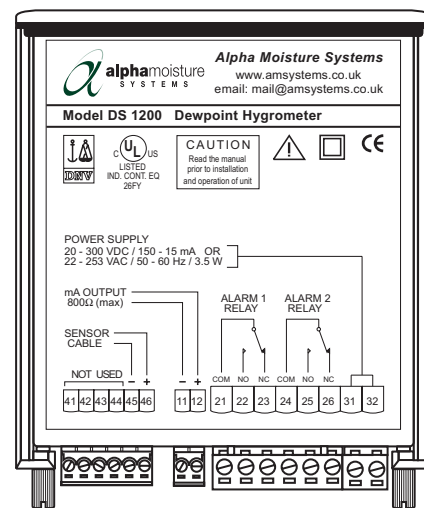

www.amsystems.co.uk

Product specification may be subject to change, without prior notice, as part of our ongoing product development programme.